

Operating and installation instructions

Strainer

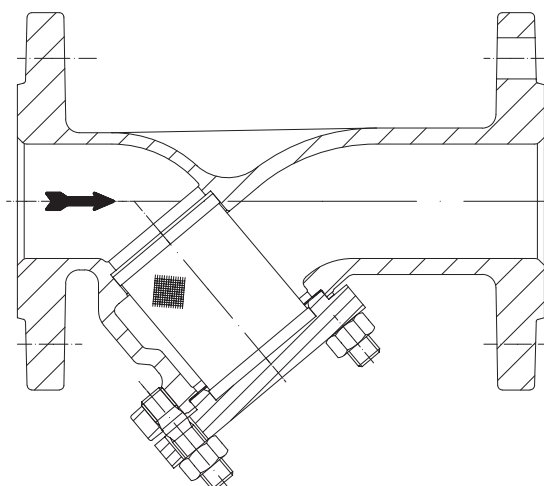
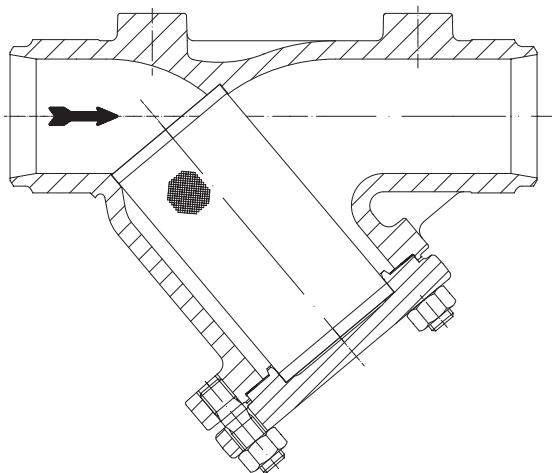
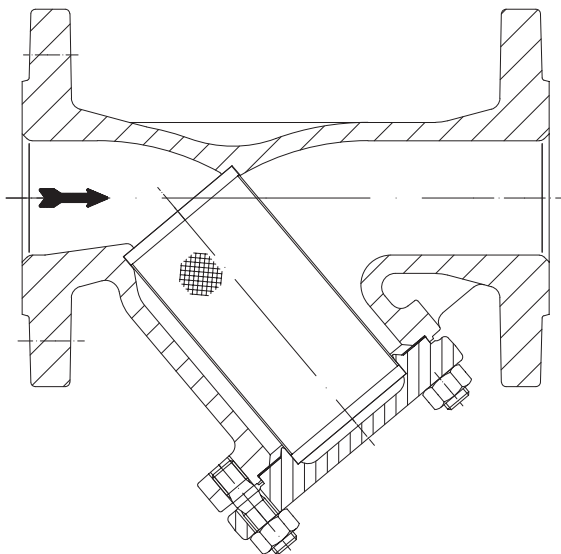

Contents

1.0 General information on operating instructions	2	6.0 Putting the valve into operation	6
2.0 Notes on possible dangers	2	7.0 Care and maintenance	6
2.1 Significance of symbols	2	8.0 Troubleshooting	7
2.2 Explanatory notes on safety information	2	9.0 Troubleshooting table	7
3.0 Storage and transport	2	10.0 Dismantling the valve or the top part	8
4.0 Description	3	11.0 Warranty / Guarantee	8
4.1 Scope of applications	3	12.0 EC declaration of conformity	9
4.2 Operating principles	3		
4.3 Diagram	4		
4.4 Technical data - remarks	4		
4.5 Marking	5		
5.0 Installation	5		
5.1 General notes on installation	5		
5.2 Installing valves with butt weld ends	6		

1.0 General information on operating instructions

These operating instructions provide information on mounting and maintaining the fittings. Please contact the supplier or the manufacturer in case of problems which cannot be solved by reference to the operating instructions.

They are binding on the transport, storage, installation, start-up, operation, maintenance and repair.

The notes and warnings must be observed and adhered to.

- Handling and all work must be carried out by expert personnel or all activities must be supervised and checked.

It is the owner's responsibility to define areas of responsibility and competence and to monitor the personnel.

- In addition, current regional safety requirements must be applied and observed when taking the fittings out of service as well as when maintaining and repairing them.

The manufacturer reserves the right to introduce technical modifications at any time.

These Operating Instructions comply with the requirements of EU Directives.

2.0 Notes on possible dangers

2.1 Significance of symbols



Warning of general danger.

2.2 Explanatory notes on safety information

In these Operating and Installation Instructions dangers, risks and items of safety information are highlighted to attract special attention.

Information marked with the above symbol and "**ATTENTION !**" describe practices, a failure to comply with which can result in serious injury or danger of death for users or third parties or in material damage to the system or the environment. It is vital to comply with these practices and to monitor compliance.

All other information not specifically emphasised such as transport, installation, operating and maintenance instructions as well as technical data (in the operating instructions, product documentation and on the device itself) must also be complied with to the fullest extent in order to avoid faults which in turn can cause serious injury to persons or damage to property.

3.0 Storage and transport

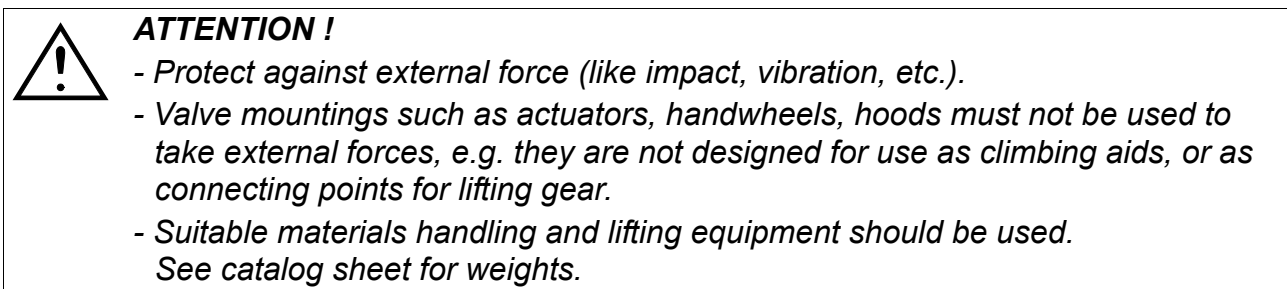

- At -20°C to +65°C.

- The paint is a base coat to protect against corrosion during transportation and storage. Do not damage paint protection.

4.0 Description

4.1 Scope of applications

Strainers are used for "cleanin flowing mediums".



ATTENTION !

- Refer to the data sheet for applications, limits on use and possibilities.
- Certain media require or preclude the use of special materials.
- The valves are designed for standard operating conditions. If conditions exceed these requirements, e.g. aggressive or abrasive media, the operator should state the higher requirements when ordering.
- Valves made from grey cast iron are not authorised for use in systems subject to TRD 110.

The information complies to the Pressure Equipment Directive 97/23/EC.

It is the responsibility of the machine planner to ensure compliance.

The special markings on the valve must be taken into account.

Refer to the catalogue sheet to see which materials are used in standard versions.

Please contact the supplier or the manufacturer if you have any questions.

4.2 Operating principles

The medium flows through the strainer screen in the direction shown on the strainer and is thereby cleaned.

4.3 Diagram

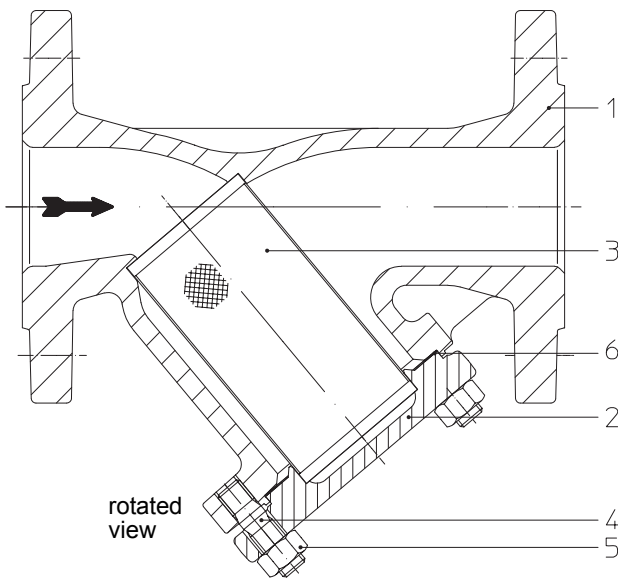

fig. 1: Strainer - Y

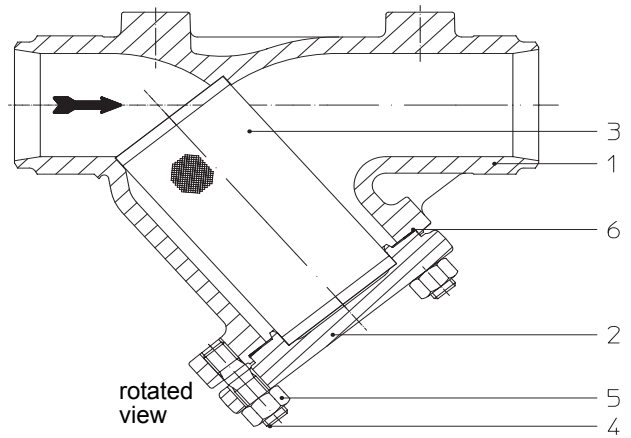

fig. 2: Strainer - Y SE

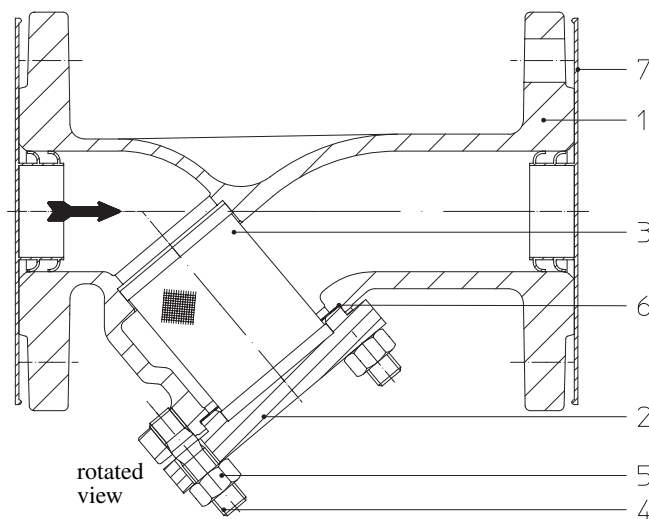

fig. 3: Strainer - Y (1.4408)

Refer to the data sheet for information about materials with designations and figure numbers.

4.4 Technical data - remarks

for

- Principal dimensions
- Pressure-temperature-ratings
- Valves with butt weld ends, etc. refer to datasheet.

4.5 Marking

Details of the CE-marking on the valve:

 CE-marking

0525 Notified body



Manufacturer

Address of manufacturer:

Typ Type

refer to item 11.0 Warranty / Guarantee

Bj. Year of manufacture

According to the Pressure Equipment Directive table 6, annex II, valves without safety function are only allowed to bear the CE-marking DN32 onwards.

5.0 Installation

5.1 General notes on installation

The following points should be taken into account besides the general principles governing installation work:



ATTENTION !

- *Remove flange covers if present.*
- *The interior of valve and pipeline must be free from foreign particles.*
- *Note installation position with reference to flow direction, see mark on valve.*
- *Steam line systems should be designed to prevent water accumulation.*
- *Lay pipelines so that damaging transverse, bending and torsional forces are avoided.*
- *Protect valves from dirt during construction work.*
- *Connection flanges must mate exactly.*
- *Connecting bolts for pipe flanges should be mounted preferably from the counter flange side (hexagon nuts from the valve side).*
At DN15-32: If valves should be mounted directly to valves, the upper flange connecting bolts should be preferably executed with studs and hexagon nuts on both sides.
- *Valve mountings such as actuators, handwheels, hoods must not be used to take external forces, e.g. they are not designed for use as climbing aids, or as connecting points for lifting gear.*
- *Suitable materials handling and lifting equipment should be used.*
See data sheet for weights.
- *Leave sufficient space to remove the screen basket during installation in pipelines.*
- *Installation position:*
 - a) *The screen basket should never be at the top, otherwise the dirt will fall back into the pipe.*
 - b) *If water hammer is possible due to condensation in steam lines, never install the trap with the screen basket at the bottom, but install it so that it is horizontal.*
- *Centre gaskets between the flanges.*
- *Install compensators to compensate for thermal expansion of the piping.*

- Planners / construction companies or operators are responsible for positioning and installing products.

- The valves are designed for application, not influenced from weather.

- For application outside or in adverse environments like corrosion-promoting conditions (sea water, chemical vapours, etc.), special constructions or protective measures are recommended.

5.2 Installing valves with butt weld ends

Please note that only qualified persons using appropriate equipment and working in accordance with technical rules are allowed to install fittings by welding. The responsibility for this lies with the system owner.

Refer to the data sheet for information about the shape of the butt weld ends.

6.0 Putting the valve into operation



ATTENTION !

- *Before putting the valve into operation, check material, pressure, temperature and direction of flow.*
 - *Regional safety instructions must be adhered to.*
 - *Residues in piping and valves (dirt, weld beads, etc.) inevitably lead to leakage.*
 - *Touching the valve when it is operating at high (> 50°C) or low (< 0°C) media temperatures can cause injury.*
Affix warning notice or protective insulation as appropriate!
- Before putting a new plant into operation or restarting a plant after repairs or modification, always make sure that:*
- *All works has been completed!*
 - *The valve is in the correct position for its function.*
 - *Safety devices have been attached.*

7.0 Care and maintenance

The strainer screens must be cleaned regularly. Maintenance and maintenance-intervals have to be defined by the operator and depends on the degree of dirt accumulation in the system.

- If necessary, the strainer can be fitted with an additional start-up filter (e.g. filter with supporting basket) to start up the system.
- Flush the plant thoroughly before starting it.
- The strainer requires little maintenance.



ATTENTION !

Refer to point 10.0 before opening the strainer.

- *Contaminated strainers in suction-lines will result cavitation and damage the pumps.*

- Before reassembling the unit, remember that the bearing surface must be cleaned and a new gasket (pos. 6) must be inserted.
- Set the strainer cover (pos. 2) in place.
- Tighten the hexagon nuts (pos. 4) evenly crosswise.

Tightening torque's for hexagon nuts / bolts:

DN	hexagon nuts / bolts	Torque (Nm)
15- 32	M 10	20-35
40	M 12	20-35
50- 65	M 12	60-80
80-150	M 16	100-125
200	M 20	150-200
250-400	M 24	340-410
500	M 27	340-410

8.0 Troubleshooting

In the event of malfunction or faulty operating performance check that the installation and adjustment work has been carried out and completed in accordance with these Operating Instructions.



ATTENTION !
It is essential that the safety regulations are observed when identifying faults.

If malfunctions cannot be eliminated with the help of the following table "9.0 troubleshooting table", the supplier or manufacturer should be consulted.

9.0 Troubleshooting table



ATTENTION !
- read point 10.0 and 11.0 prior to dismantling and repair work!
- read point 6.0 before restarting the plant !

Fault	Possible cause	Corrective measures
No flow	Flange covers have not been removed (7, Fig. 3)	Remove flange covers (7, Fig. 3)
Flow too low	strainer clogged.	Clean/replace screen.
	Piping clogged.	Check piping system.
Flange broken between unit and piping	Bolts tightened unevenly. Mating flanges not properly aligned.	Re-align piping and fit new valve!

10.0 Dismantling the valve or the top part



ATTENTION !

The following points must be observed:

- *Pressureless pipe system.*
- *Medium must be cool.*
- *Plant must be drained.*
- *Purge piping systems in case of caustic, inflammable, aggressive or toxic media.*

11.0 Warranty / Guarantee

The extent and period of warranty cover are specified in the "Standard Terms and Conditions of Albert Richter GmbH & Co. KG" valid at the time of delivery or, by way of departure, in the contract of sale itself.

We guarantee freedom of faults in compliance with state-of-the-art technology and the confirmed application.

No warranty claims can be made for any damage caused as the result of incorrect handling or disregard of operating and installation instructions, datasheets and relevant regulations.

This warranty also does not cover any damage which occurs during operation under conditions deviating from those laid down by specifications or other agreements.

Justified complaints will be eliminated by repair carried out by us or by a specialist appointed by us.

No claims will be accepted beyond the scope of this warranty. The right to replacement delivery is excluded.

The warranty shall not cover maintenance work, installation of external parts, design modifications or natural wear.

Any damage incurred during transport should not be reported to us but *rather* to the competent cargo-handling depot, the railway company or carrier company immediately or else claims for replacements from these companies will be invalidated.



Technology for the Future.

GERMAN QUALITY VALVES

ARI-Armaturen Albert Richter GmbH & Co. KG, D-33756 Schloß Holte-Stukenbrock

Telephone (+49 5207) 994-0 Telefax (+49 5207) 994-158 or 159

Internet: <http://www.ari-armaturen.com> E-mail: info.vertrieb@ari-armaturen.com

12.0 EC declaration of conformity

ARI-Armaturen Albert Richter GmbH & Co. KG,
Mergelheide 56-60, D-33756 Schloß Holte-Stukenbrock

EG-Konformitätserklärung
im Sinne der
EG-Druckgeräterichtlinie 97/23/EG und

Hiermit erklären wir,

dass gemäß der oben genannten Druckgeräterichtlinie die nachfolgend aufgelisteten Produkte ausgeführt sind und nach Diagramm 6, Anhang II, Modul H der Druckgeräterichtlinie von Lloyd's Register Quality Assurance GmbH (BS-Nr. 0525), Am Sandtorkai 41, D-20457 Hamburg, geprüft wurden.

Zertifikat-Nr: 50003/1

Schmutzfänger
Typ 050, 059, 080

Angewendete Normen:

DIN 3840

AD 2000 Merkblatt A4

- Gusseisen mit Kugelgraphit
- Stahlguss
- Schmiedestahl

Schloß Holte-Stukenbrock, den 11.01.2010

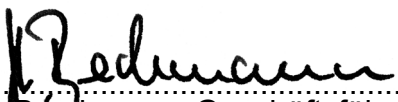
.....
(Bedermann, Geschäftsführer)